

volupte

Volupte studio

Calle Amanuel,2o
28004 Madrid

hola@soyvolupte.com

soyvolupte.com
[@voluptestudio](#)



CHALLENGING THE ACT OF DESIGN IN A FUTURE WORLD

- 01. *About us*
- 02. *Process*
- 03. *Services*
- 04. *Past Projects*
- 05. *Products*

volupte studio

WE ARE A **RESEARCH** AND *PRODUCT DESIGN STUDIO* IN MADRID THAT EXPLORES GEOGRAPHIC FORMS THROUGH PROCESS AND RITUAL. WE WANT TO BRING A DIFFERENT KIND OF SENSUALITY THROUGH THE *UNION OF EMPATHY AND OBJECT*.

Our work is based on the fusion of materiality and functional design inspired by our **Mediterranean** upbringing, merging craft, nature and beauty. We aim for our pieces to create their *own identity* inspired through a **raw materiality** that **brings sensuality**. Focusing on the process, we want our pieces to reflect a **senso-ry voyage**, always alive and in motion.

We offer **bespoke services** from unique pieces, series to installations. Our clients range from individuals for their **personal homes, to restaurants, hotels, and fashion brands**. Our work is always based on a unique blend of material/ process and the client's need

We work with *natural materials*, sourcing biomaterials from a mixture of urban and rural environments depending on the project. We are inspired by **ecosystems of the periphery**, or the places unseen, questioning the *hierarchy of value that we are accustomed to*. We want to create value through story and process, giving voice to material. By doing so, it gives us the opportunity to create sustainability, through organic shapes and forms that reach **sensuality and pleasure**.

We live and work in Madrid, but seek project focus in the countryside of our childhood homes in southern France, and Bulgaria.

Eloise and Alexandra,
co-founders of Volupte Studio



At our most fundamental, VOLUPTE Studio is about **Research.**

olupte's work is united by an underlying attention to detail, surface, and form. We research material and products as we approach life-

*What makes us connect ?
What makes us feel good ?
What makes us feel alive ?*

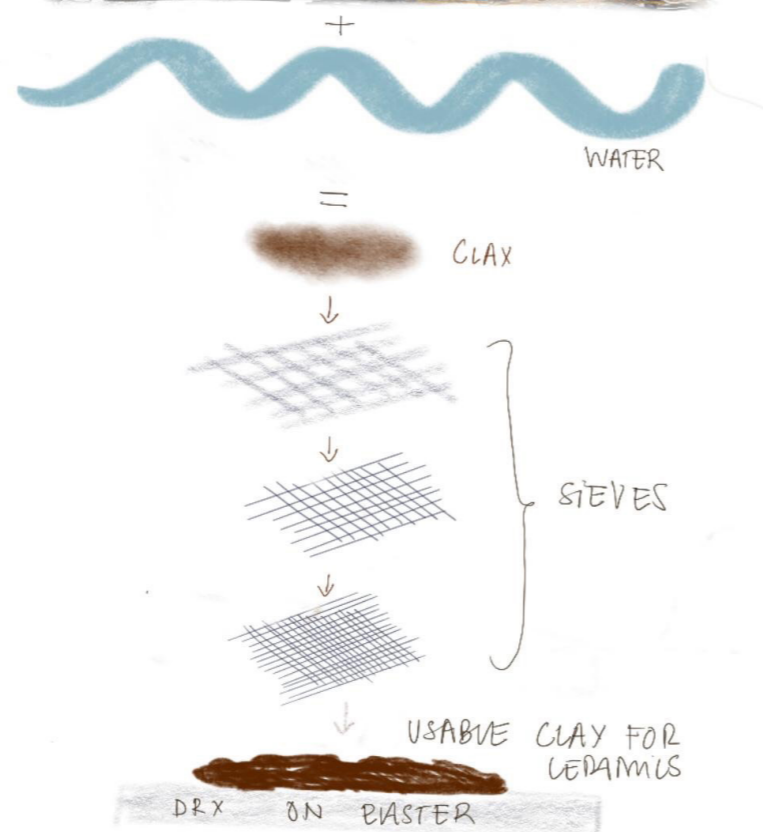

We offer a range of services that begin with investigation to final product realization, ranging from a scale of a singular and unique object to the large-scale production.

1/MATERIAL RESEARCH

Natural and local materials incorporated into the development of product design and production.

2/BESPOKE

We design and produce all our products, giving us flexibility to meet our clients needs. We can create unique designs or produce at scale, making us unlimited in time or design.

3/INTERIOR CONCEPTUALIZATION/ SET DESIGN

With our knowledge of materials, we happily take on projects to redesign and reconceptualize ephemeral or permanent spaces.



1/MATERIAL RESEARCH

[Material Sensibility] We explore new senses to *experience a material*- **algae, ash, sand, stone, wood**. We conceptualize our notion of what is a material to remake, reform how we create with limited resources today.

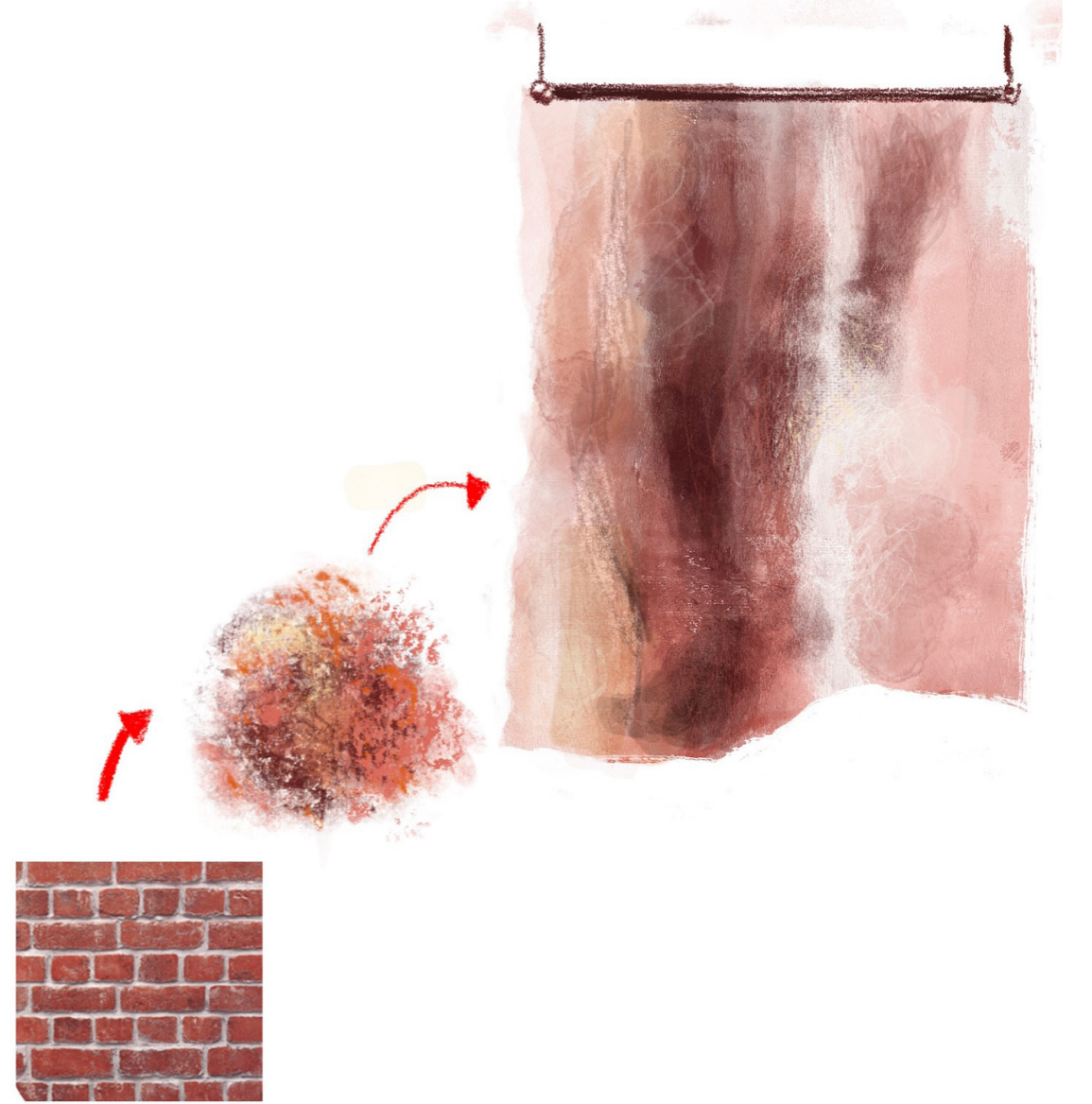
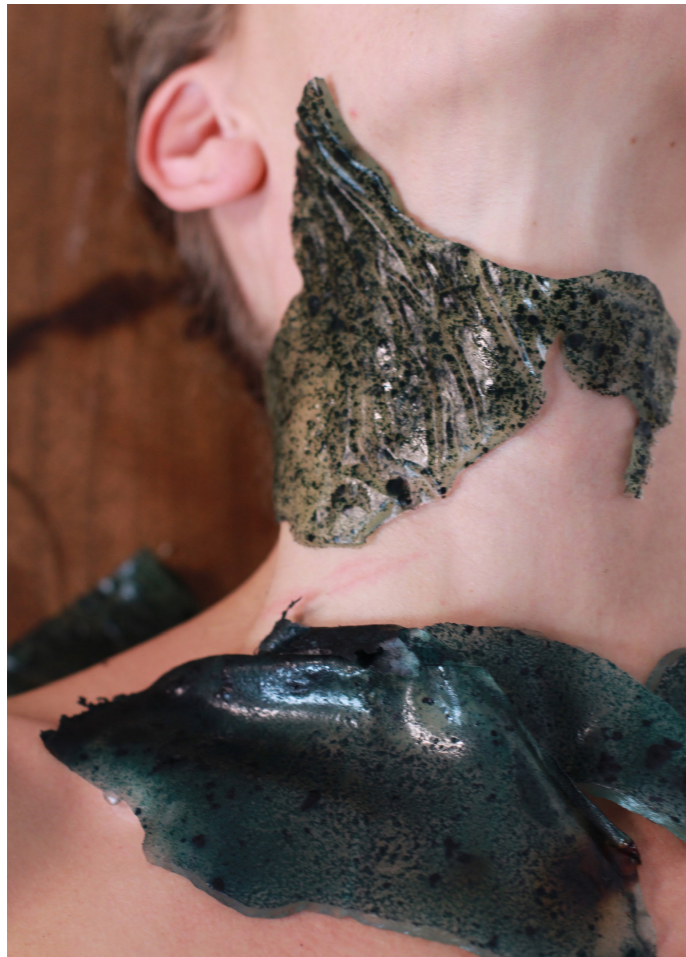

2/BESPOKE

[Bringing life into the inanimate] We offer *bespoke services*, making any product design a reality. We accompany our clients on their journey **from inspiration to production**, whether it be a unique piece or a large order for personal or business use. Our ethos of beauty and simplicity is always experienced through our attention *to process and incorporation of natural and/or local materials* where possible.



3/INTERIOR CONCEPTUALIZATION/ SET DESIGN

[Making space into Place] Inspired by our surroundings, we welcome the opportunity to **design moments around and beyond an object's shape.** We have worked with fashion and lifestyle brands that share a similar ethos to ours to **create visual experiences** that transcend type or object.





Volupte x Tramo

[tableware]

Our client, *TRAMO restaurant*, entrusted us with their tableware for their fine dining restaurant. We created over a **thousand pieces** from our studio in Madrid. We used their *construction site waste*, transformed it into clay and created a unique clay body for all their work.



Volupte X Atelier Lucie Patarozzi

[material research]

We received EU funding for our project of using river clay that we collected from the *Garonne River*, France. We **investigated, sourced** and **transformed** earth collected from the river into usable and safe clay that we could use to create a series of decorative objects.



Volupte X Edit Napoli 2023

[Palette of sustainability]

We presented our work of exploring brining *concepts of sustainability and wellbeing into luxury interior design.*

The project is about an open research on natural, innovative, circular, and sustainable materials for restaurants, homes, friendly with the planet and people.

Using food waste, we created **natural glazes** from *mussel shells, eggshells and orange peels* to create **dishwash safe tableware** with unique coloring *reminiscent of mediterranean summers.*





WE USED CONSTRUCTION SITE WASTE TO CREATE A SERIES OF DECORATIVE VASES.



05.

PRODUCTS

We make products for that most intimate part of yourself. We design spaces that fill our lives with sensuality



Collection *Languir* presents handmade tableware objects, with different kind of color and textures, with modern and elegant lines

MATERIALS: Sandstone
TECHNICS: Moldes & wheel
COOKING: Electric 1250°C
COLORS: Several shades of white, cream, clear brown, light brick & the glaze shiny or mat.
(possible to use other colors according to the customer's taste)

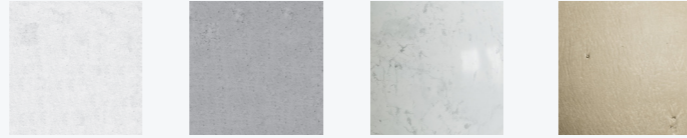

USES AND MAINTENANCE:

Microwave: Yes
 Dishwasher: Yes
 Oven: No (avoid above 100°)
 Food: Yes.

Bandeja Gualda

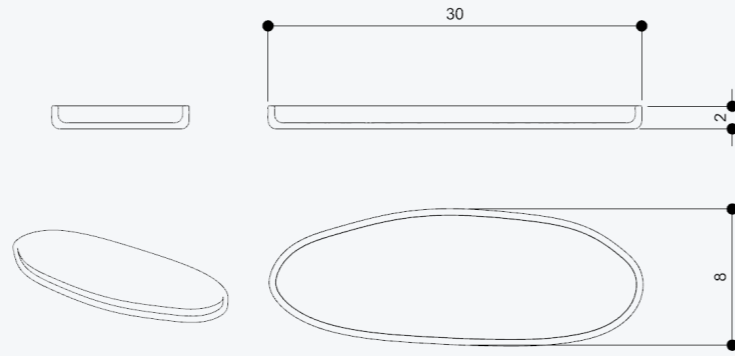
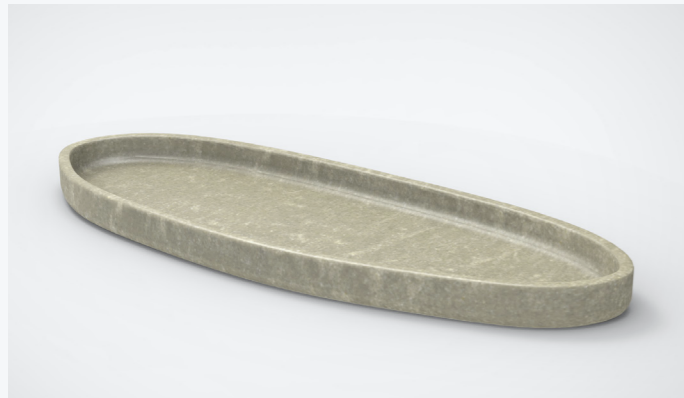

Dimensions: Ø 30cm, height 2cm, width 8cm

Plato recto Manuel

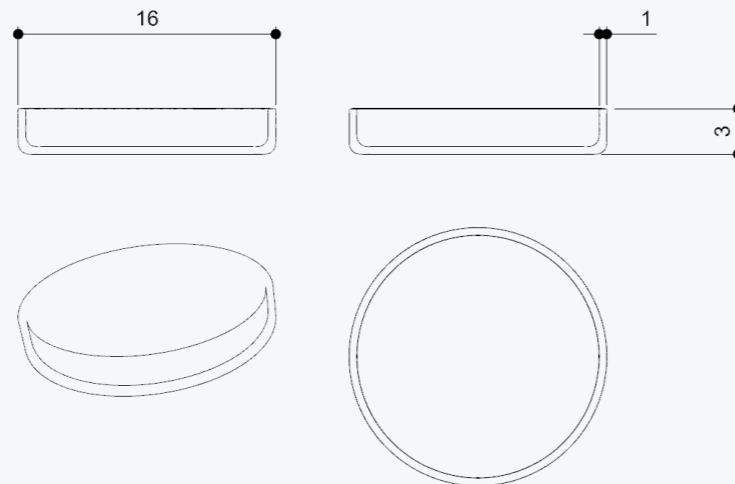

Dimensions: Ø 16cm, height 3cm

Plato grande Amaniël

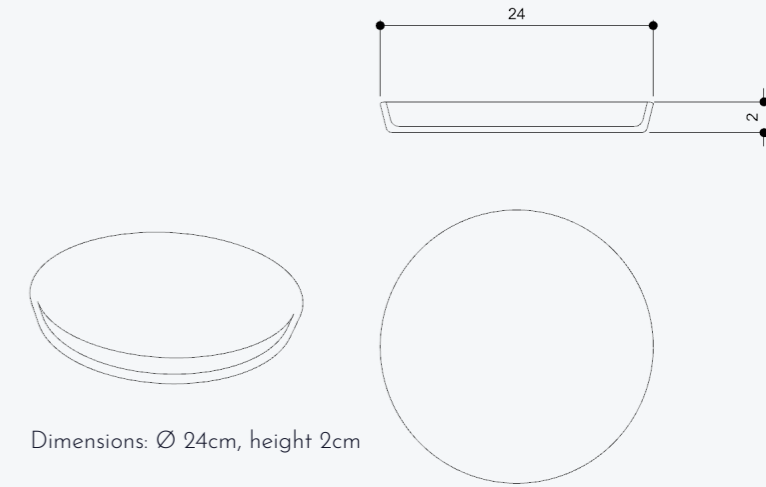

Dimensions: Ø 24cm, height 2cm

Plato medium Quiñones

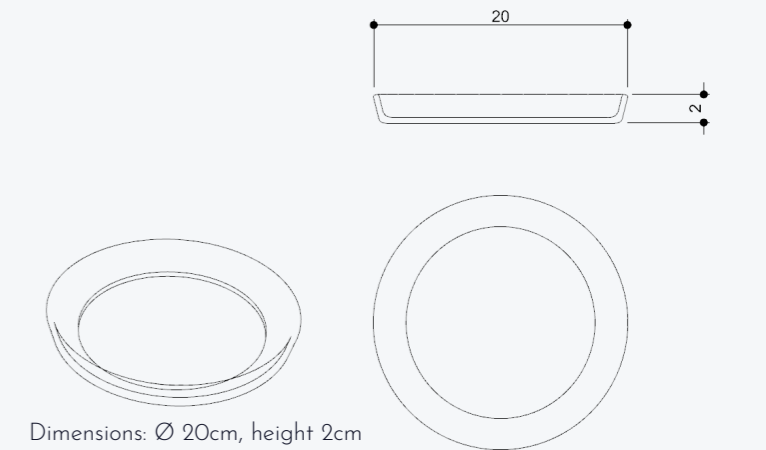

Dimensions: Ø 20cm, height 2cm

Plato pequeño Minas

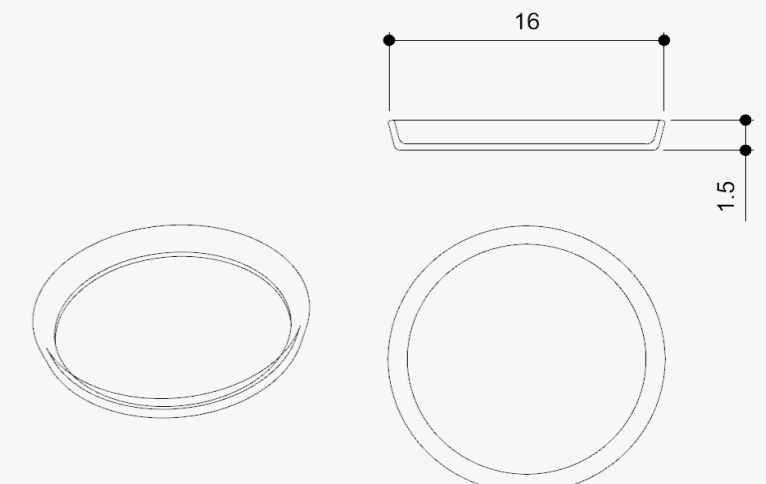

Dimensions: Ø 16cm, height 1,5cm

05.

PRODUCTS

Big bowl *Villa*

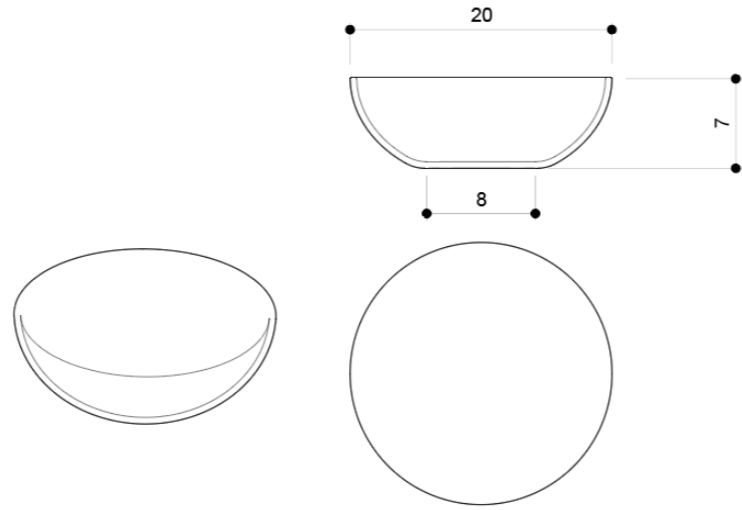

Dimensions: Ø 20cm, height 7cm, bottom 8cm

Small bowl *Luna*

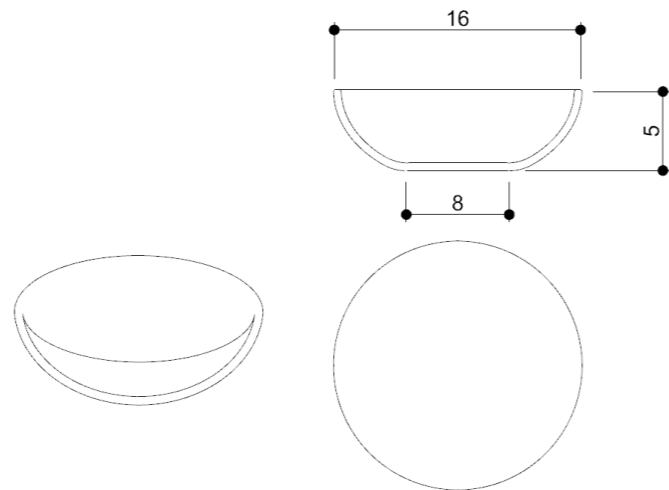

Dimensions: Ø 16cm, height 5cm, bottom 8cm

Coquette *Nao*

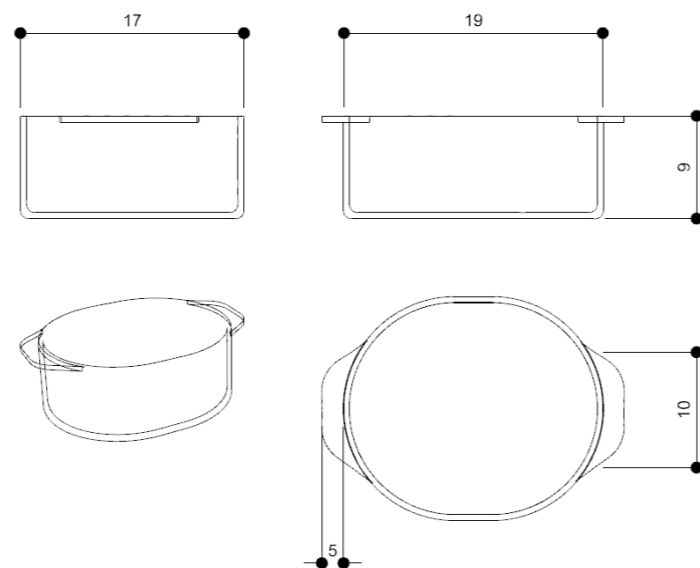

Dimensions: Ø 19cm, height 9cm, width 17cm

Jug *San Pablo*

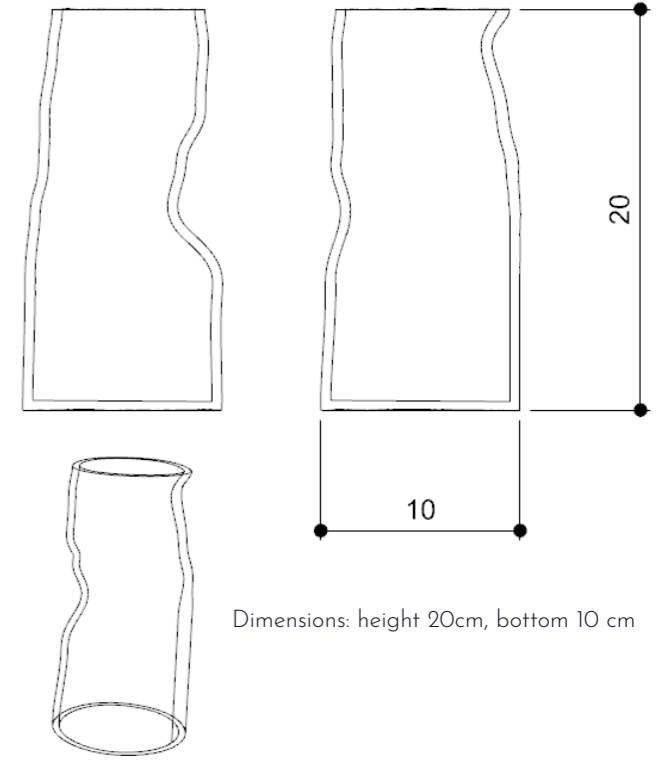

Dimensions: height 20cm, bottom 10 cm

Cup *Barco*

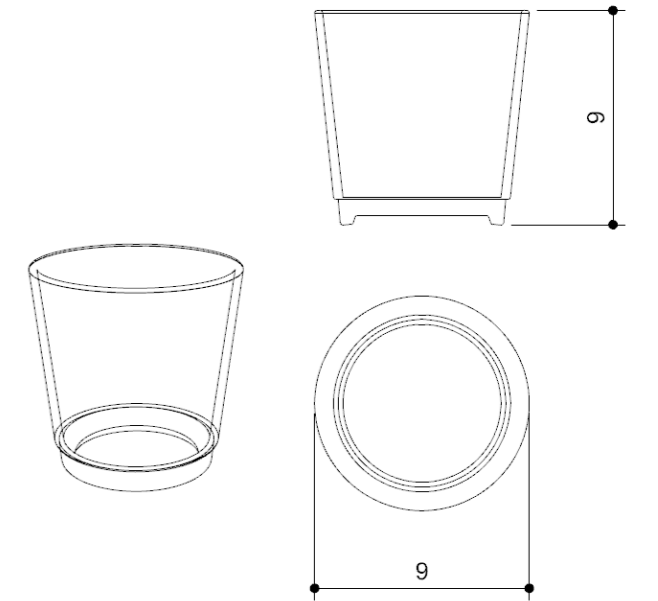

9

volupte

We are inspired by those in our life who love and live un-apologetically. We love celebrations and the good times, *but Volupte is a tribute to the beauty and the poetry to the moments in between.*